

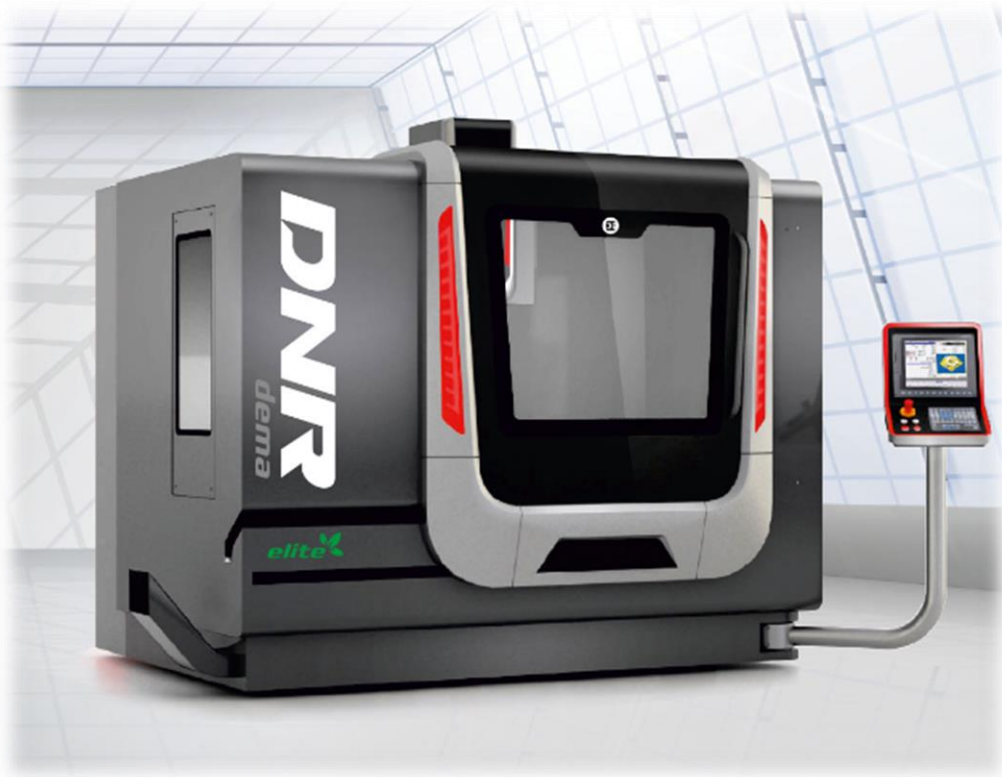

Hidrofleks

Hortum, Hidrolik ve Pnömatik

CNC & TALAŞLI İMALAT



Hidrofleks olarak makine tasarım ve üretimi ile başlayan talaşlı imalat kapasitemizi dik işlem merkezi yatırımımız ile daha kapsamlı hale getirmiş bulunuyoruz. Artık müşterilerimizin standart veya özel imalat gerektiren taleplerine daha hızlı, daha ekonomik ve kaliteden ödün vermediğimiz bütüncül çözümler üretiyoruz...



CNC Dikey İşleme Merkezimizde; 1200*600*600 mm'ye kadar çelik, pirinç, alüminyum, paslanmaz, pvc ve benzeri neredeyse tüm imalata uygun malzemeleri işleyebiliyoruz.

Bu malzemeler için; elle serbest çizimle belirlenen formların işlenmesi, hassas frezeleme, delik delme, havuz boşaltma ve ölçülendirme işlemlerini yapabilmekteyiz.

Nihai ürün olarak;

- Özel Tasarım Makine Parçaları,
- Tablalar,
- Hidrolik & Pnömatik Bloklar, Kollektörler,
- Özel Rekorlar ve bağlantı parçalarının üretimleri konusunda müşterilerimize destek veriyoruz.

TASARIM & TEKNİK ÇİZİM

Müşterilerimizin standart ve özel ölçülü taleplerini; tecrübeli Teknik ekibimizle Solidworks ve CAD programlarıyla 3 Boyutlu tasarımını ve teknik çizimlerini yaparak imalat öncesinde görmelerini sağlıyoruz.

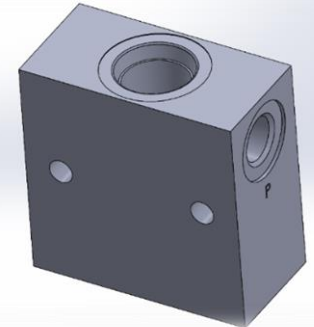
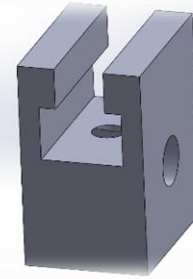
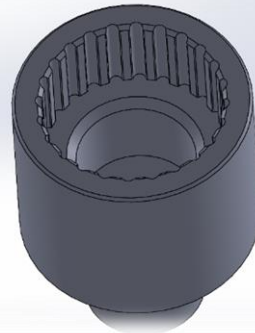
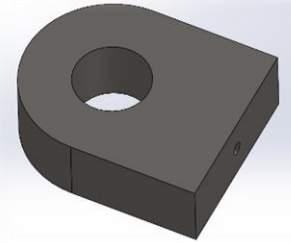
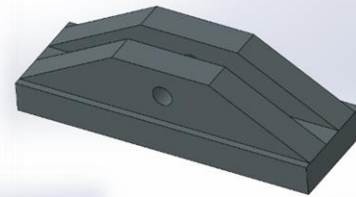
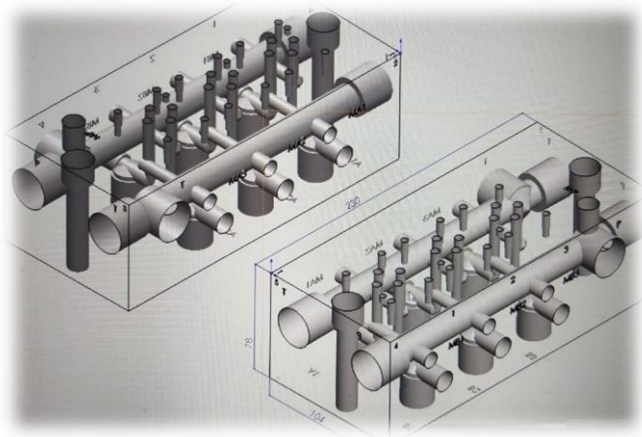
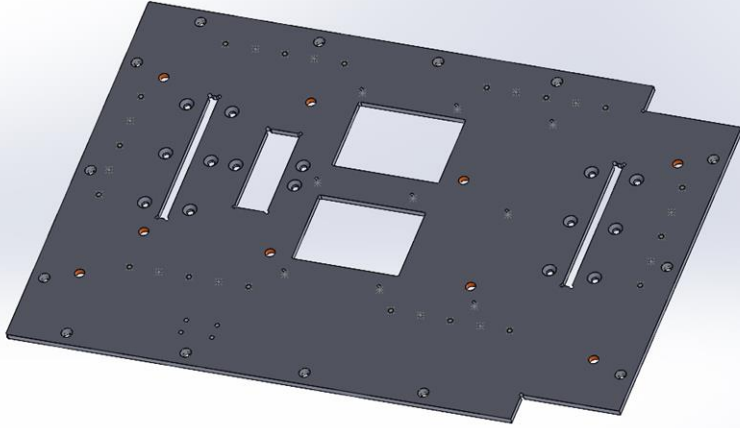

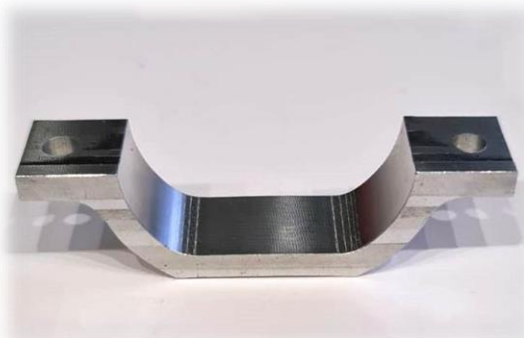
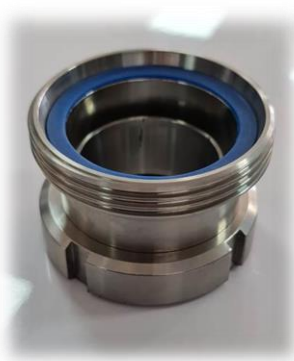

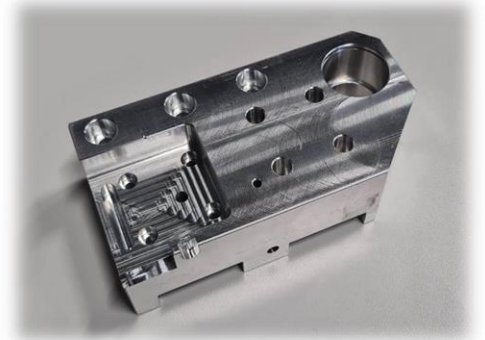

3D MODELLEME

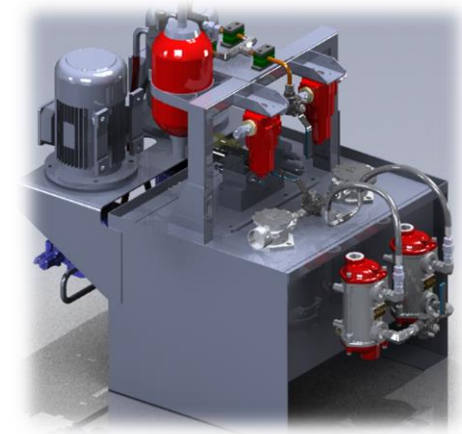
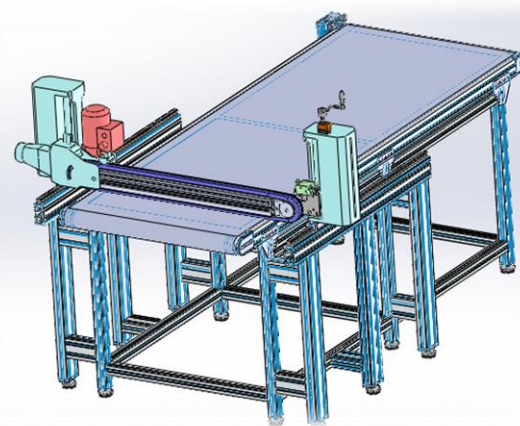
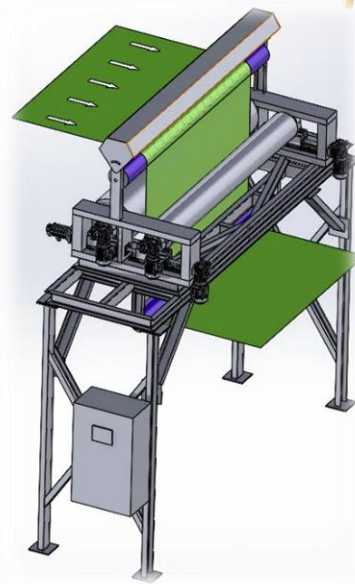
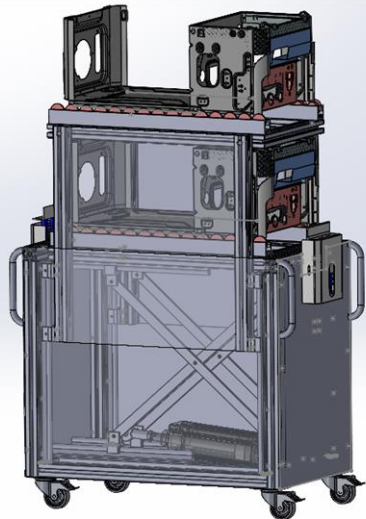
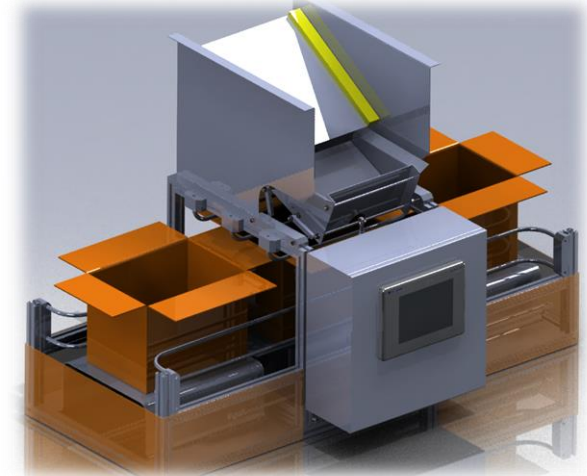
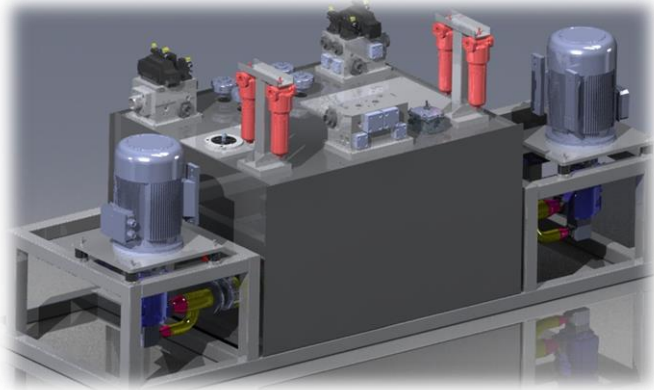

ÖZEL MAKİNE TASARIMI & İMALATI

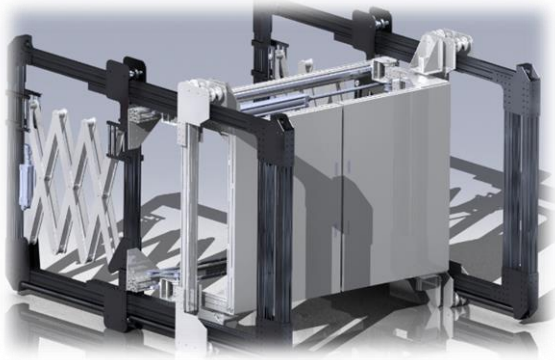

* XL İTİCİ PLAKA MAKİNESİ



* HİDROLİK PRES

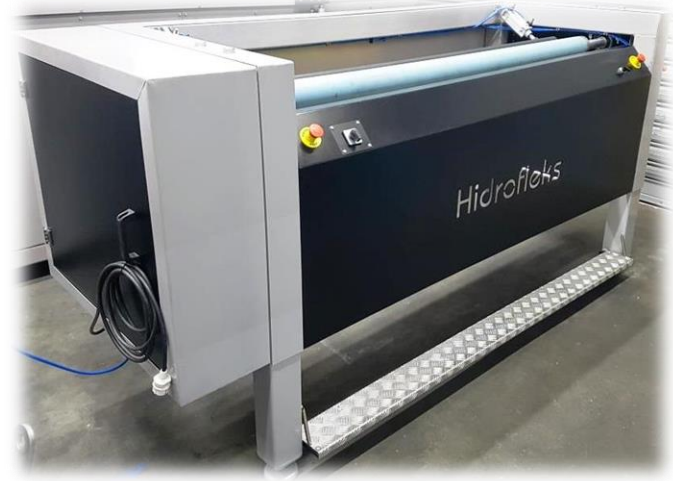

* FLEX PLATE DEMOUNTER



* PVC EMBOSsing SYSTEM



* SOLVENTLİ SİLİNDİR
YIKAMA MAKİNESİ